



# 420 SERIES

## THERMAL BREAK ALUMINUM SLIDING GLASS DOOR ASSEMBLY AND INSTALLATION INSTRUCTIONS

Effective 7/31/17

**TACOMA, WA**  
**(253) 922-6030**

**PORTLAND, OR**  
**(503) 682-3270**

**MARYSVILLE, WA**  
**(360) 659-0836**

**SACRAMENTO, CA**  
**(916) 635-0700**

**TEMECULA, CA**  
**(951) 296-1400**

**SIMI VALLEY, CA**  
**(805) 581-6325**

**LAS VEGAS, NV**  
**(702) 453-1234**

**DENVER, CO**  
**(303) 365-5520**

**SALT LAKE CITY, UT**  
**(801) 972-0715**

**PHOENIX, AZ**  
**(480) 763-6000**

**SUGAR GROVE, IL**  
**(253) 896-8040**

**GRAND PRAIRIE, TX**  
**(817)-525-2601**

### 420 Door Configurations

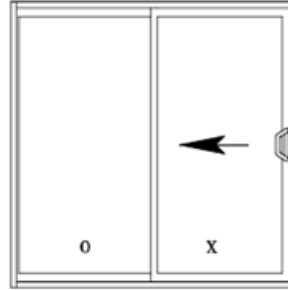

2-PANEL  
0X (X0)

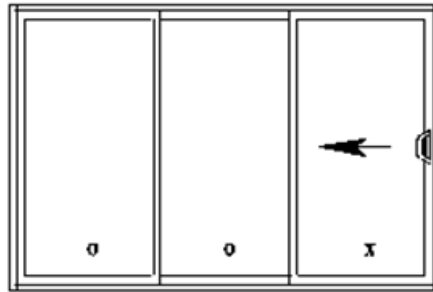

3-PANEL  
00X (X00)

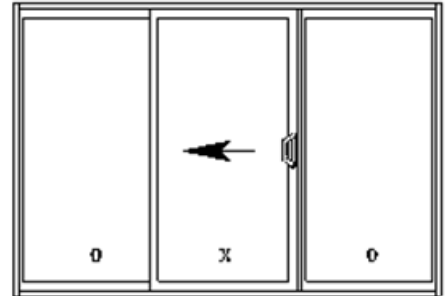

3-PANEL  
0X0

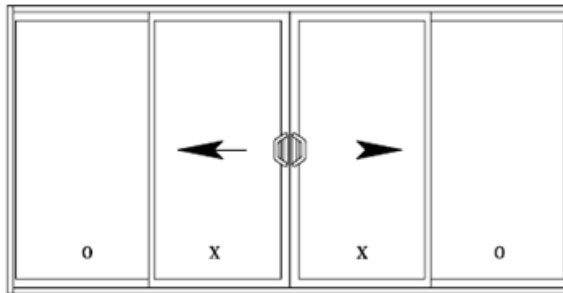

4-PANEL  
0XX0

## 420 KD DOOR PARTS LIST

**IMPORTANT:**

BEFORE STARTING THE INSTALLATION OF THE DOOR, PLEASE READ THROUGH THE INSTRUCTIONS. VERIFY THAT YOU HAVE THE REQUIRED PARTS FOR YOUR DOOR CONFIGURATION AND ANY OPTIONAL PARTS THAT MAY BE REQUIRED FOR YOUR PARTICULAR INSTALLATION. IF YOU ARE USING OPTIONAL PARTS FOR YOUR DOOR CONFIGURATION, REFER TO THE "OPTIONAL COMPONENTS ASSEMBLY" ON THE FACING PAGE FOR INSTRUCTION PRIOR TO STARTING.

**REQUIRED PARTS**

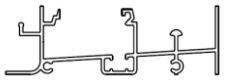

SILL – EX4200  
QTY = 1-OX, OOX, OXO, OXXO

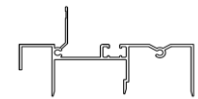

HEAD – EX4210  
QTY = 1-OX, OOX, OXO, OXXO

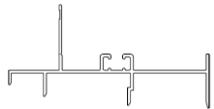

JAMB – EX4220  
QTY = 2-OX, OOX, OXO, OXXO

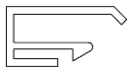

CAP – VA0403XX  
QTY = 3-OX, OOX, OXO, 2-OXXO



NAIL-FIN CORNER SEAL  
(Do Not Remove) – LA0218MM  
QTY = 2



SILL TRACK COVER – VA0404  
QTY = 1-OX, OOX, OXO, OXXO



ANTI-LIFT - VA5279XX  
QTY = 2-OX, OOX, OXO 4-OXXO

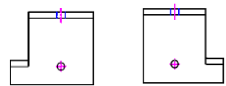

FIXED PANEL CLIP  
FA0120 – LH & FA0119 - RH  
QTY = 1-OXO, 2-OXXO, 3- OOX



FIXED PANEL L-CLIP – FA0108CP  
QTY = 1-OX, OOX, 2-OXO, OXXO

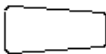

SASH BUMPER – HA0165MI  
QTY = 1-OX, OOX, OXO, 2-OXXO



SILL WEEP GATE  
HOUSING – IM8511CVBZ  
QTY = 4-OX, 6-OOX, OXO, 8-OXXO

**REQUIRED PARTS**

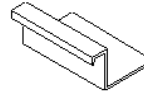

JAMB RETAINER CLIP – HA4261  
QTY = 3-OX, 6-OXO, 6-OOX  
6-OXXO

**OPTIONAL PARTS**

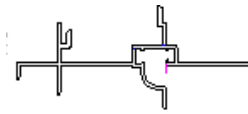

3 PANEL ADAPTER  
EX4230  
QTY = 1-OXO, 1 OOX

**FASTENERS FOR FRAMES AND PARTS**

	<u>XOO</u>	<u>OOX</u>		
#8-32 Bronze Cap Nut	3	3		
#8-32 Thread x 1/4 "	2	2		
#8-32 Thread x 1 1/4"	1	1	<u>XO</u>	<u>OOX</u>
#6 x 3/4" Bronze Head	0	5	5	0
#8 x 1/2" Bronze Head	6	12	12	12
#8 x 1/2"	2	4	4	4
#8 x 1-1/4"	1	1	1	2
#8 x 1-1/2"	10	10	10	10
#8 x 2-1/2"	6	0	0	0

# COMPONENTS ASSEMBLY

## STEP 1 USED ON ALL CONFIGURATIONS

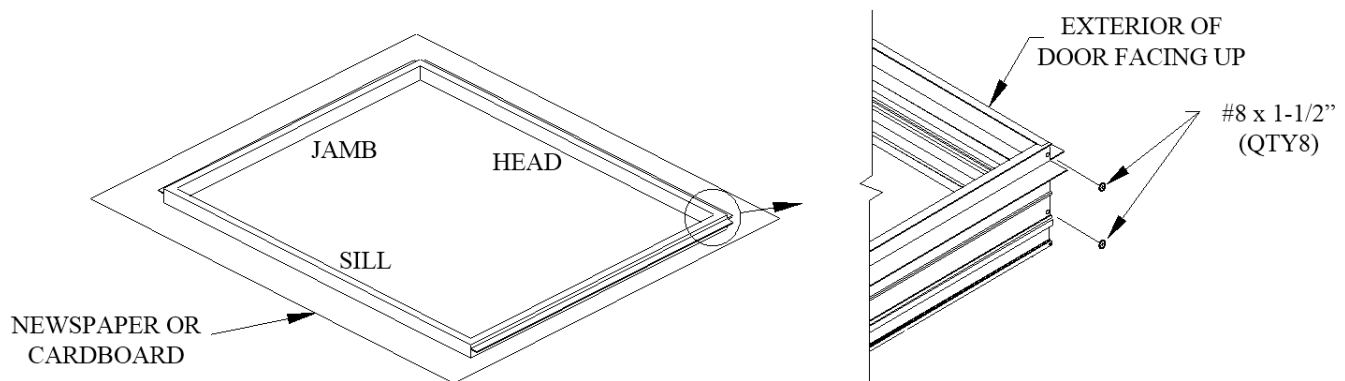

### FRAME ASSEMBLY:

1. WITH THE FRAME PARTS LAID OUT ON CARDBOARD OR NEWSPAPER, AND THE EXTERIOR FACING UP (NAIL-FIN FARTHEST FROM THE FLOOR).
2. FASTEN THE FRAME TOGETHER AT THE CORNERS WITH (2) #8 X 1 ½" SCREWS AT EACH CORNER.
3. TIGHTEN SCREWS ALL THE WAY TO ENSURE A PROPER SEAL OF THE PREINSTALLED GASKETS.

**WARNING! OVERTIGHTENING THE SCREWS WILL RESULT IN THE HEAD OF THE SCREW BREAKING OFF, AND THE REMAINING SCREW WILL BE INSIDE THE ALUMINUM PROFILE.**

4. THEN APPLY SILICONE AT THE HEAD (EX4210) /JAMB (EX4220) CORNERS, FROM THE BASE OF THE FRAME TO THE OUTERMOST EDGE OF THE NAIL FIN CONNECTION.

NOTE: EXTERIOR WIDTH OF DOOR FRAME IS 5/8" SMALLER THAN NET FRAME WIDTH. REVERSING DOOR HANDING WILL REQUIRE NEW DOOR PANELS OR MAY VOID THE MILGARD WARRANTY.

## STEP 2 USED ON ALL CONFIGURATIONS

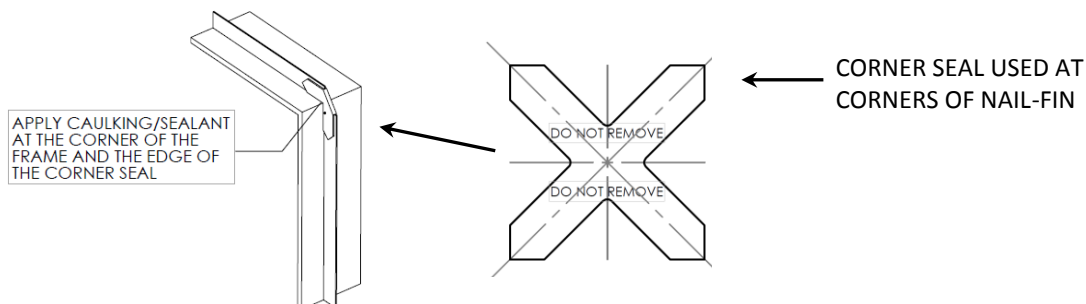

### NAIL FIN CORNER SEAL:

AFTER THE FRAME IS FASTENED TOGETHER, FOLD THE CORNER SEALS OVER THE NAIL FIN AT THE CORNERS OF THE HEAD AND JAMB.

APPLY CAULK AT THE CORNER OF THE FRAME AND THE EDGE OF THE CORNER SEAL.

**IMPORTANT:** THIS PROVIDES A BARRIER TO STOP MOISTURE FROM GETTING INTO AND BEHIND THE DOOR.

## STEP 3

## USED ON ALL CONFIGURATIONS

NOTE: FOR DOORS 6'0" WIDE USE (1) TUBE OF SEALANT, WIDER DOORS USE (2) TUBES OF SEALANT

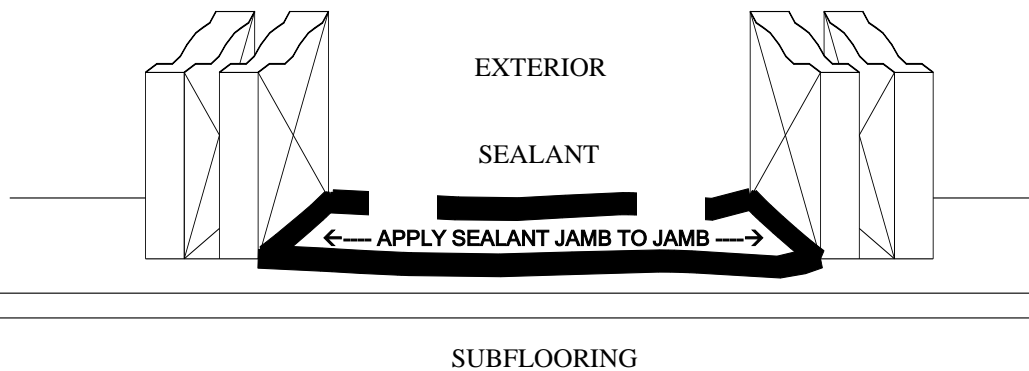

**NOTE:**  
WHEN INSTALLING ON  
CONCRETE, A MOISTURE  
BARRIER MUST BE  
INSTALLED TO PROTECT THE  
DOOR SILL FROM  
CORRODING.

### SILL SEALANT APPLICATION:

1. APPLY 2 OR 3 3/8" NOMINAL SIZE BEADS OF CONSTRUCTION SEALANT ON THE FLOOR FROM JAMB TO JAMB DIRECTLY UNDER SILL (EX4200).
2. RUN ADDITIONAL SEALANT ACROSS EACH END OF THE WALL SILL PLATE SO THE BOTTOM CORNERS OF THE DOOR FRAME WILL BE BURIED IN SEALANT AT OUTERMOST CORNERS, LEAVING 2 GAPS IN SEALANT ON THE OUTSIDE AS SHOWN ABOVE FOR POSSIBLE DRAINAGE.

PLEASE REFERENCE [AAMA 2400](#) AND [ASTM E2112](#) FOR INSTALLATIONS.

## STEP 4

## USED ON ALL CONFIGURATIONS

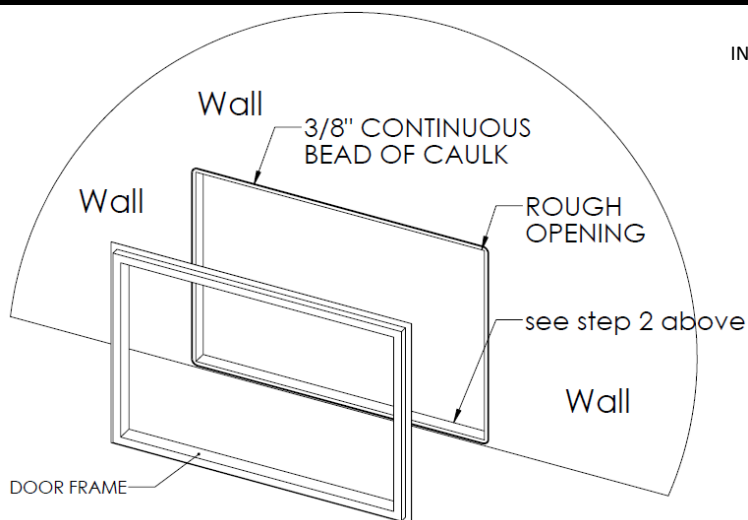

### INSTALLING FRAME IN OPENING:

Recommend dry-fitting before final install

1. APPLY CAULKING/SEALANT
2. USING A WIDE/FLAT HEAD NAIL, TACK THROUGH THE HEAD NAIL-FIN INTO THE HEADER.
3. VERIFY SILL IS LEVEL, SHIMMING AS REQUIRED.
4. VERIFY JAMBS ARE PLUMB; LEAVING 1/4" CLEARANCE ON EACH SIDE.
5. MEASURE FRAME DIAGONALLY FOR SQUARENESS.
6. NAIL JAMB AND SILL NAIL FIN WITH WIDE/FLAT HEAD GALV. NAILS AT 8" O.C. MAX.
7. COVER NAIL FIN WITH 9" MIN. FLASHING PAPER IN WATERBOARD FASHION.

Measure diagonally to check square and plumb dimensions

### ASSEMBLED FRAME INSTALLATION:

PRIOR TO INSTALLING FRAME, RUN A 3/8" CONTINUOUS BEAD OF CONSTRUCTION SEALANT AROUND ROUGH OPENING WITHIN 1/2" OF EDGE. PUT THE FRAME INTO THE OPENING AND PUSH SECURELY INTO PLACE SO THE NAIL FIN EMBEDS INTO SEALANT. (REFERENCE DETAILS ABOVE, AAMA 2400 AND ASTM E2112)

PLEASE REFERENCE [AAMA 2400](#) AND [ASTM E2112](#) FOR INSTALLATIONS.

**STEP 5****USED ON OX, XOO, OOX CONFIGURATIONS ONLY****FRAME JAMB & LOCK STRIKER INSTALLATION:**

1. AFTER DOOR HAS BEEN INSTALLED PROPERLY USE THE 4 - 2 ½" SCREWS PROVIDED TO SECURE FRAME LOCK JAMB TO WALL STUD
2. 4 - PRE-FABRICATED HOLES HAVE BEEN PROVIDED FOR THIS PROCESS THERE IS 2 OF THESE HOLES THAT SUPPORT THE LOCK STRIKER AND TWO OTHER HOLES WHICH ARE ABOVE AND BELOW THIS STRIKER.
3. AFTER FRAME HAS BEEN SECURED TO WALL STUD ADD THE 2- 2 ½" SCREWS TO THE FRAME STRIKER, THERE ARE TWO SLOTS PROVIDED IN STRIKER FOR THESE. MAKE SURE THAT DOOR PANEL LOCK IS ALIGNED AND FUNCTIONAL BEFORE SECURE THESE LAST TWO SCREWS.

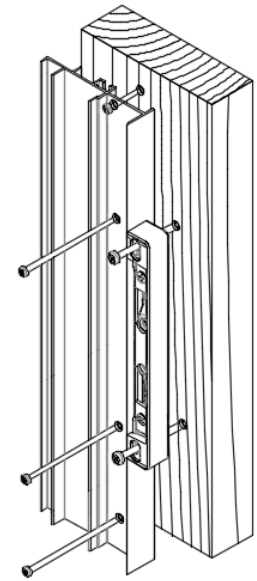
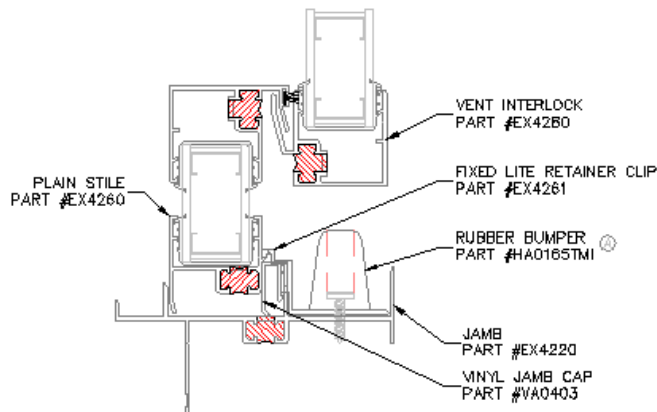
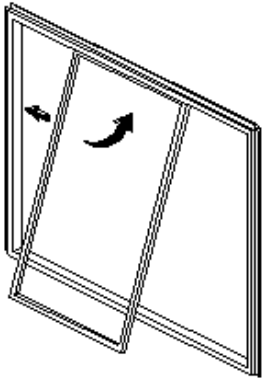
**STEP 6****USED ON ALL CONFIGURATIONS****FIXED PANEL INSTALLATION OX, OXO, OXOX:**

SET THE FIXED PANEL INTO POSITION FROM THE OUTSIDE OF THE FRAME BY INSERTING THE TOP AND SWINGING THE BOTTOM IN, SETTING IT INTO THE GROVES IN THE SILL AND PUSHING IT TIGHT AGAINST THE JAMB.

**FIXED PANEL INSTALLATION OOX:**

INSERT THE JAMB CAP (VA0403) ON THE JAMB WHERE THE FIXED PANEL BUTTS AGAINST FRAME. SET THE FIXED PANEL INTO POSITION FROM THE INSIDE OF THE FRAME BY INSERTING THE TOP AND SWINGING THE BOTTOM IN, SETTING IT INTO THE GROVES IN THE SILL AND PUSHING IT TIGHT AGAINST THE JAMB.

## STEP 7

*USED ON OX, OXO, OXXO ; FOR OOX, PROCEED TO STEP 9*

### SECURING FIXED PANEL TO JAMB:

1. USING THE PROVIDED, FIXED PANEL RETAINER CLIP (EX2208), SECURE THE FIXED PANEL.
2. ON NON-LOCKING SIDE, INSTALL THE TOP & BOTTOM RETAINER CLIPS WITH (2) #8 X 1/2" BRONZE HEAD SELF TAPPING SCREWS PROVIDED IN THE DOOR KIT AS SHOWN.
3. POSITION CENTER CLIP BETWEEN THE HEAD AND SILL WITH DOOR STOPPER OVER CENTER CLIP.
4. ATTACH DOOR BUMPER & CENTER CLIP USING A #8 X 1-1/4" SCREW.
5. REFER TO CONFIGURATION DIAGRAMS ON THE LAST PAGE FOR ALL DOOR STOP PLACEMENTS.

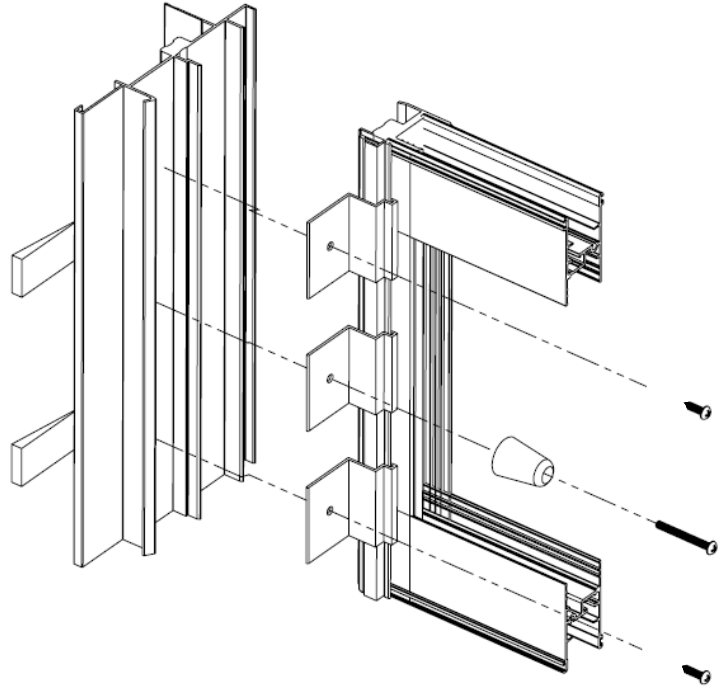

## STEP 8

*USED ON ALL CONFIGURATIONS*

APPLY SILICONE TO GAP BETWEEN FRAME AND TOP OF PANEL

### L-CLIP INSTALLATION:

INSTALL THE L-CLIP WITH TAB (FA0120 or FA0119) AT THE TOP OF EACH FIXED PANEL WITH TAB FACING INSIDE AS SHOWN AND SECURE TO PANEL WITH (1) #8 x 1/2" BRONZE HEAD SCREW.

INSTALL SECOND SCREW THROUGH CLIP AND INTO HEAD OF DOOR FRAME.

INSTALL THE L-CLIP (FA0108CP) AT THE BOTTOM OF EACH FIXED PANEL WITH LONG LEG UP BY ATTACHING TO INTERIOR FACE OF FIXED PANEL UNDER THE FIXED PANEL INTERLOCK WITH (1) #8 x 1/2" STAINLESS STEEL SCREW.

**NOTE: SHORT LEG OF L-CLIP (FA0108CP) SHOULD SIT ON DOOR SILL POCKET TOWER/WATER COLUMN BETWEEN THE FIXED AND VENT OF FRAME SILL PROFILE WHERE VINYL SLEEVE COVER ALUMINUM PROFILE.**

ATTACH TO SILL USING (1) #8 x 1/2" STAINLESS STEEL SCREW.

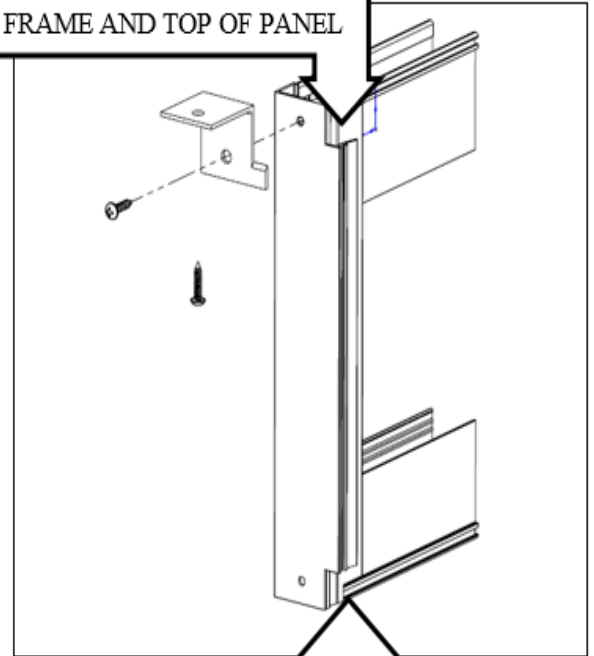

APPLY SILICONE ALONG PANEL & FRAME CONNECTION AFTER PANEL HAS BEEN SECURED

## STEP 9

*USED ON OOX ONLY; OTHER CONFIGS PROCEED TO STEP 11*

### SECURING FIXED PANEL TO JAMB & 3 PANEL ADAPTER TO FIXED PANEL

1. INSTALL 1<sup>ST</sup> FIXED PANEL INTO FRAME OPENING.
2. SLIDE THE FIXED PANEL AGAINST THE FRAME JAMB.
3. USE (3) #8 x 1/2" BRONZE HEAD SCREWS TO SECURE EX4261 CLIPS, PANEL TO FRAME. PLACEMENT IN 3 EQUAL POSITIONS
4. INSTALL 2<sup>ND</sup> FIXED PANEL WITH INTERLOCK STILE INTO FRAME OPENING
5. SLIDE THE FIXED PANEL AGAINST 3 PANEL ADAPTER
6. USE (2) #8 - 1/4" BRONZE HEAD SCREWS & CAP NUTS TO SECURE EX4261 CLIPS, PANEL TO ADAPTER ON TOP & BOTTOM. SAME AS STEP 3. ABOVE (HOLES ARE PROVIDED IN ADAPTER)
7. ATTACH DOOR BUMPER & CENTER CLIP USE (1) #8 - 1 1/4" SCREW & CAP NUT. PLACEMENT IN MIDDLE OF DOOR HEIGHT SEE DRAWING
8. INSTALL VENT PANEL INTO FRAME AND ADJUST WHEELS TO ALIGN PANEL WITH FRAME JAMB AND STRIKER
9. PRE-DRILL (5) 1/8" EQUALLY SPACED HOLES THROUGH ADAPTER INTO FIXED PANEL.
10. USE (5) # 6 x 3/4" BRONZE HEAD SCREWS TO SECURE ADAPTER TO FIXED PANEL.

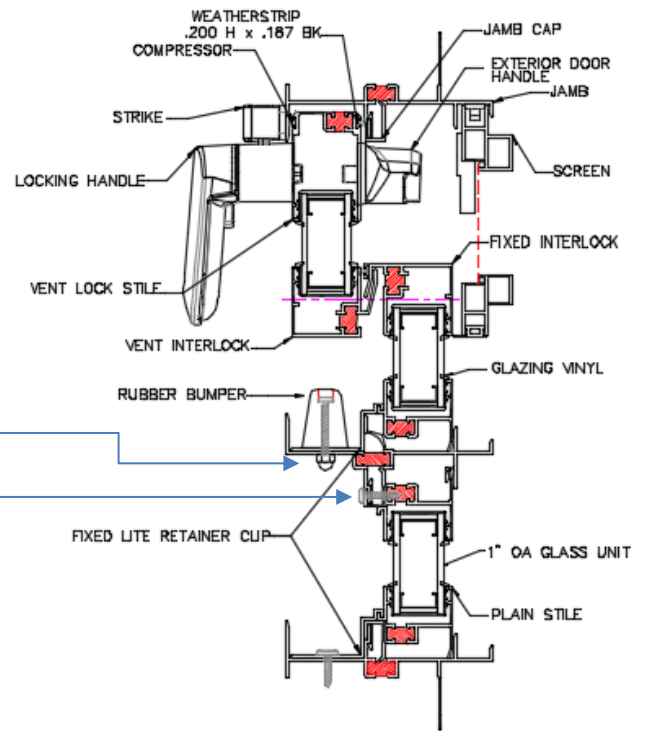

## STEP 10

*USED ON OXO ONLY; OTHER CONFIGS PROCEED TO STEP 11*

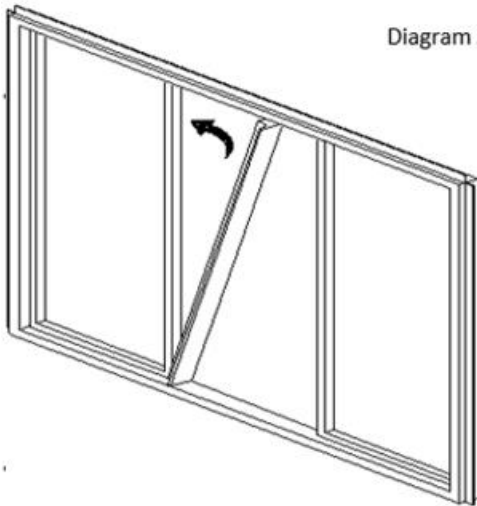
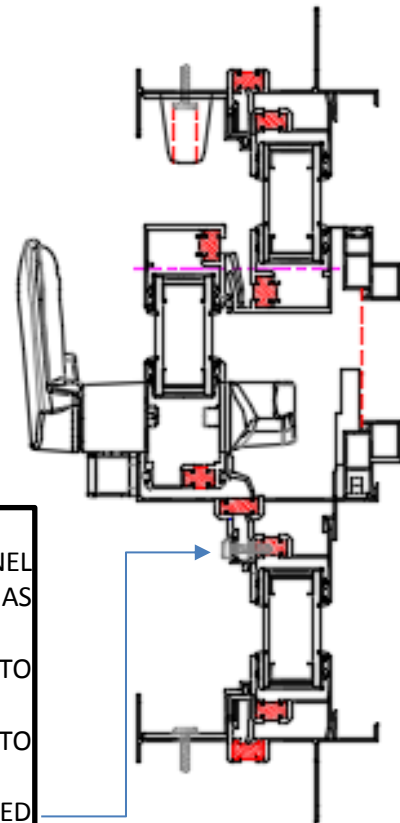

Diagram A

### 3-PANEL ADAPTER INSTALLATION:

1. ONCE BOTH FIXED PANELS ARE SECURED INTO PLACE, TAKE THE 3-PANEL ADAPTER (EX4230) ASSEMBLY (SEE DIAGRAM "A"), AND ORIENT AS SHOWN.
2. ANGLE THE BOTTOM INTO THE SILL FIRST AND ROTATE THE TOP INTO PLACE. PUSH TIGHT AGAINST THE PANEL.
3. PRE-DRILL (5) 1/8" EQUALLY SPACED HOLES THROUGH ADAPTER INTO FIXED PANEL.
4. USE (5) #6 x 3/4" BRONZE HEAD SCREWS TO SECURE ADAPTER TO FIXED PANEL.



## STEP 11

## USED ON ALL CONFIGURATIONS

### VENT PANEL INSTALLATION:

1. SET VENT PANEL INTO POSITION FROM INSIDE OF FRAME BY INSERTING TOP FIRST AND SWINGING IN BOTTOM.
2. OPERATE VENT PANEL TO VERIFY ROLLERS ARE CORRECTLY RIDING ON TRACK; SHOULD SLIDE SMOOTHLY.
3. USING A WIDE, FLAT, STIFF PUTTY KNIFE OR A SECOND PERSON TO LIFT THE PANEL SLIGHTLY WHILE ADJUSTING (*this removes the panel weight from the rollers preventing adjustment screws from stripping and makes adjusting easier*); INSERT #2 PHILIP SCREW DRIVER INTO HOLES AT EACH BOTTOM END OF VENT TO ADJUST HEIGHT OF VENT PANEL.
4. ADJUST SO LOCK STILES ARE PARALLEL TO JAMB AND INTERLOCKS. ON A 4-PANEL OXO DOOR, ADJUST BOTH VENT PANELS SO THE LOCK HANDLES AND INTERLOCKS LINE UP.
5. LOWER VENT PANEL BACK DOWN ONTO THE ROLLER TRACK, CHECK ALIGNMENT AND OPERATION, REPEAT AS NECESSARY.
6. INSTALL/SNAP ANTI-LIFTS IN HEAD OF DOOR FRAME WITH VENT OPEN AND ABOVE VENT OPENING.

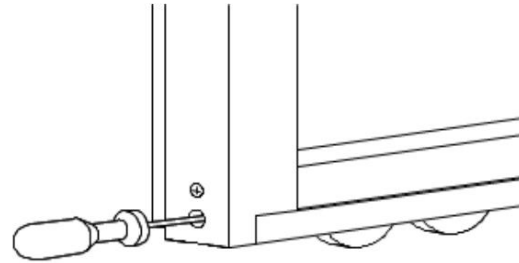
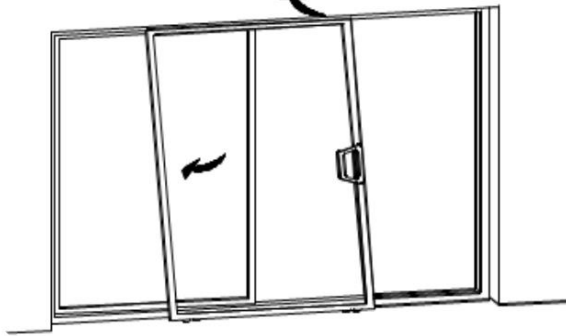

TO RAISE CORNER: TURN CLOCKWISE  
TO LOWER CORNER: TURN COUNTERCLOCKWISE

## STEP 12

## FOR KEYED LOCKS ONLY (OPTIONAL) - ALREADY INSTALLED

### INSTALLING THE LOCK KEY CYLINDER:

1. TRIM THE PIN DOWN SO THAT IT PROTRUDES 5/8" FROM THE END OF THE CYLINDER.
2. HOLDING THE LOCK CYLINDER SO THE PIN IS FACING YOU (AS SHOWN), TURN PIN ALL THE WAY CLOCKWISE UNTIL IT STOPS.
3. ORIENT THE LOCK CYLINDER TO THE EXTERIOR PULL HANDLE AS SHOWN, AND INSERT LOCK CYLINDER AS SHOWN. MAKE SURE THE PIN IS STILL ROTATED ALL THE WAY CLOCKWISE.

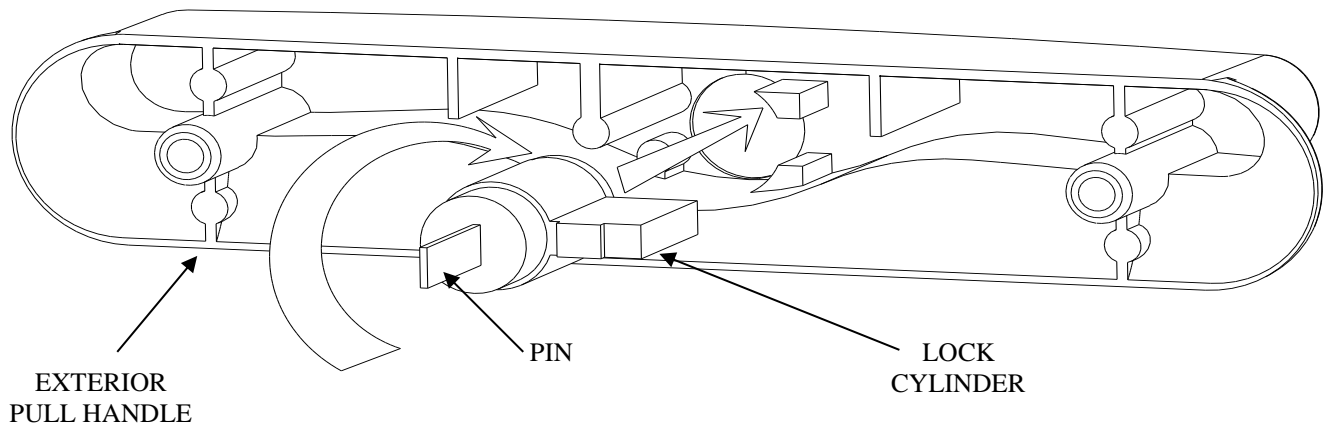



## STEP 13

## *USED ON ALL CONFIGURATIONS - ALREADY INSTALLED*

### **DOOR LOCK INSTALLATION:**

SEE ENDEAVOUR KD DOOR HANDLE AND STRIKER INSTALLATION INSTRUCTION IN HANDLE KIT BOX.

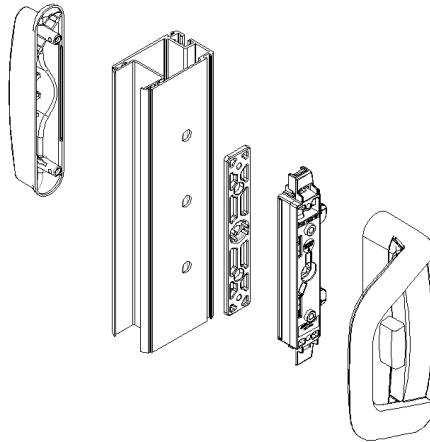

## STEP 14 *USED ON OX, OOX, OXO ONLY*

### **STRIKE AND LOCK ADJUSTMENT:**

USING MACHINE SCREWS AND BLIND NUTS IN HANDLE ASSEMBLY KIT, ATTACH STRIKE PLATE TO LOCK JAMB OF FRAME. WITH PANEL ADJUSTED; ENGAGE LOCK. IN LOCK JAMB, CENTER STRIKE WITH LOCK.

1. HOLD STRIKE IN PLACE AND SECURE STRIKE USING SUPPLIED MACHINE SCREWS AND BLIND NUTS.
2. GENTLY TIGHTEN TO SECURE IN PLACE WHILE STILL ALLOWING STRIKE MOVEMENT.
3. CHECK TO MAKE SURE THE DOOR LOCKS PROPERLY.
4. ADJUST STRIKE TO ENSURE LOCK IS FUNCTIONING PROPERLY
5. INSERT SHIMS BETWEEN THE WALL AND THE DOOR FRAME UNDER THE STRIKE AS SHOWN.
6. TIGHTEN STRIKE SCREWS TO PREVENT STRIKE MOVEMENT.

## STEP 15 *USED ON ALL CONFIGURATIONS*

### **SCREEN INSTALLATION:**

1. POSITION THE SCREEN SO THE LOCK HANDLE IS ON THE INSIDE TOWARDS THE LOCK JAMB ON OX AND OOX, AGAINST THE 3-PANEL ADAPTER ON OXO MODELS, AND FACING THE OPPOSITE SCREEN ON OXXO MODELS.
2. STANDING OUTSIDE, LIFT THE SCREEN INTO THE CHANNEL AT THE HEAD AND SWING THE BOTTOM IN AND ONTO THE SCREEN ROLLER TRACK AT THE SILL.
3. STARTING WITH THE BOTTOM, ADJUST ALL FOUR CORNERS BY INSERTING A PHILIPS SCREWDRIVER IN THE ADJUSTMENT HOLE AND TURNING CLOCKWISE TO RAISE THE WHEELS. (AT THE INTERLOCK SIDE, IT WILL BE NECESSARY TO FIRST PEEL BACK THE SOFT VINYL BUG STRIP TO GET TO THE ADJUSTMENT SCREWS.)
4. WHEN COMPLETED, THE SCREEN JAMB SHOULD BE PARALLEL WITH THE DOOR JAMB AND INTERLOCK.

